

CONGRESO INTERNACIONAL

El patrimonio epigráfico en la era digital: Documentación, análisis y socialización

ORGANIZAN:

Isabel Velázquez Soriano (Universidad Complutense)
David Espinosa Espinosa (Universidad de Santiago de Compostela)
Rosario Hernando Sobrino (Universidad Complutense)
Estela García Fernández (Universidad Complutense)

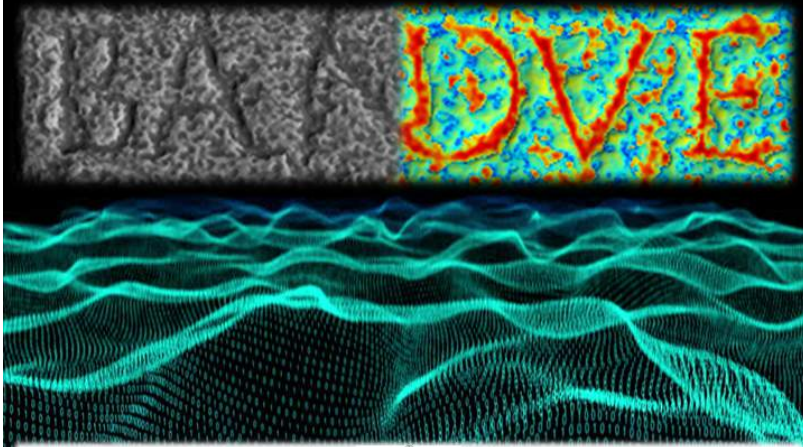

20 y 21 de junio de 2019

Salón de Grados

Facultad de Geografía e Historia
Universidad Complutense



Programa de Doctorado
en Estudios del Mundo
Antiguo (UCM-UAM) 



El oficio de epigrafista hoy: competencias básicas y avanzadas en epigrafía digital

Manuel Ramírez Sánchez
Universidad de Las Palmas de Gran Canaria
Instituto Universitario de Análisis
y Aplicaciones Textuales



MINISTERIO
DE ECONOMÍA
Y COMPETITIVIDAD

Programa Estatal de Investigación Científica y Técnica de Excelencia
Proyecto HAR2015-63637-P



www.epigrafiahumanistica.eu



fines siglo XIX



fines siglo XX

2636 Reperta in vico la Milla del Río (comuna de Llamas de la Ribera, jurisdicción de Astorga) ad Orbigo fluvium, quattuor ab Legionem et totidem ab Asturica lingua Guerra. 'Marmol pardusco, dimensiones 0,46—0,41, reperta 'no lejos del río Orrigo, juntamente con el pavimento del templo en mosaico de unos 200 píes en cuadro' Fita. Servatur Legionem in collegio S. Marci; est tabula marmorea e quattuor partibus constans. Litterae saeculi videntur esse secundi exeuntis.

in lateris:

| | | | |
|---------------------|------------|-------|---------|
| CURANTE IULIO APOLL | D | E | O |
| | VAGODONNAE | | |
| | SACRVM | RES | P |
| | AST | AVG | PER |
| | MAG | G | PACATVM |
| | ET | FL | PROELVM |
| | EX | DONIS | |

Ex ectypo per Sebastianum Olozaga v. cl. comparato mihi descripserunt Zobel et Guerra, qui edidit in bullett. inst. arch. a. 1861 p. 252; Fita 32 qui titulum lateris solus descripsit et deum hunc aliunde non notum composuit cum Orrigo fluvio, parum probabiliter. Lege: Deo Vagodonnaego sacrum. Res p(ublica) Ast(urica) Aug(usta) per mag(istros) G(avium) Pacatum et Fl(avium) Proculum ex donis. Curante Iulio Apoll(inari).

1869

The screenshot shows the Europeana Collections search interface. The search term 'donnaego' is entered in the search bar. The results page displays one result: 'Dedicación a Deo Vago Donnaego'. The result includes a thumbnail image of a stone inscription and a snippet of the Latin text: 'Deo / Vago Donnaego / sacrum res p(ublica) / Ast(urica) Aug(usta) per / mag(istros) G(avium) Pacatum / et Fl(avium) Proculum / ex donis // curante Iulio N[e]pote'. Below the text, there is a link to 'Ver en Hispania Epigraphica Online - HEpO' and a 'Texto' icon. The left sidebar shows filters for 'COLECCIONES' (Todas, 1914-1918, Art, Fashion, Maps and Geography) and 'MULTIMEDIA' (Texto (1), Solo items con enlace a los objetos). The page also includes navigation links like 'Regresar al inicio' and 'Resultados', and a 'FEEDBACK' button in the bottom right corner.

2019



Media Metadata

DESCARGAR

Título

Dedicación a Deo Vago Donnaego

MÁS ACERCA DE

Ver en Hispania Epigraphica Online - HEpOI



Descripción

Deo / Vago Donnaego / sacrum res p(ublica) / Ast(urica) Aug(usta) per / mag(istros) G(aium) Pacatum / et F(avium) Proculum / ex donis // curante Iulio N[e]pote

¿PUEDO USARLO?

FEEDBACK



2014

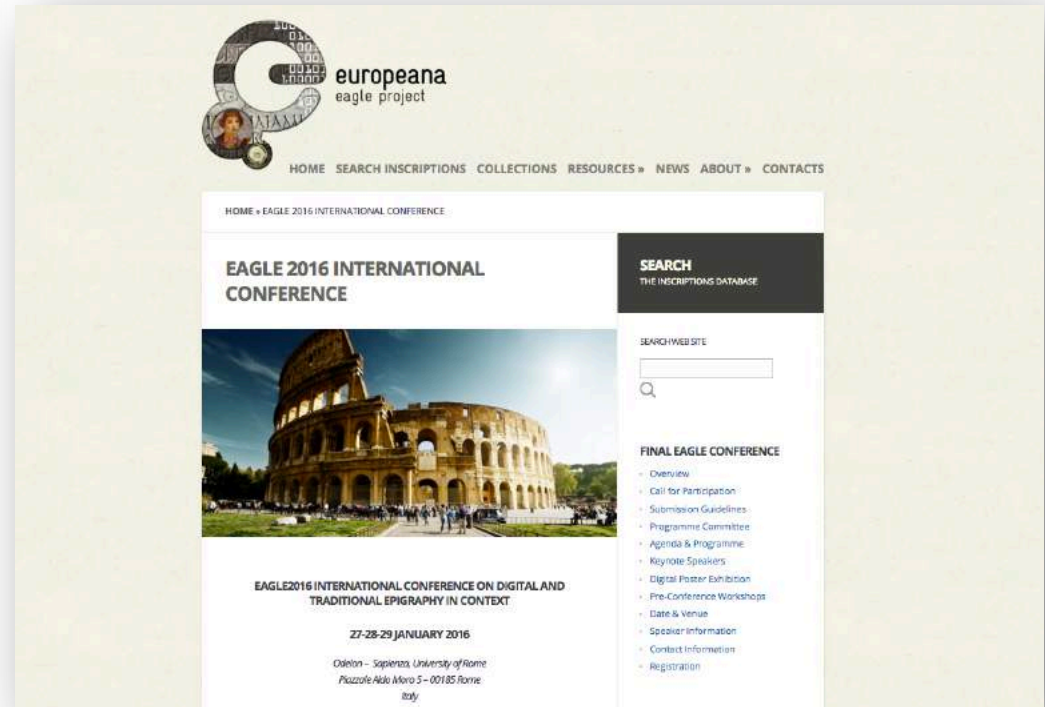

2016

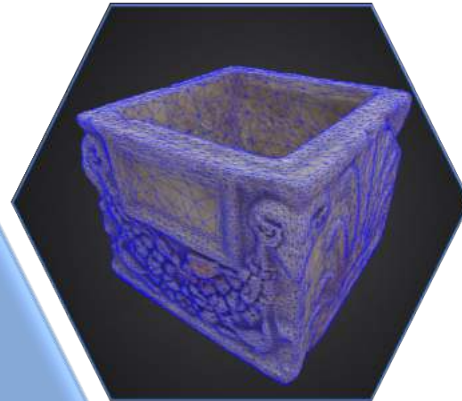

Epigrafía
digital

Trasvase de la
investigación
a la docencia

```
<span n="1" />  
<gap reason="lost" ex  
<span n="2" />  
<supplied reason="lost"  
nobilissi  
/supplied>  
nclear reason=""
```

Alfabetización
digital



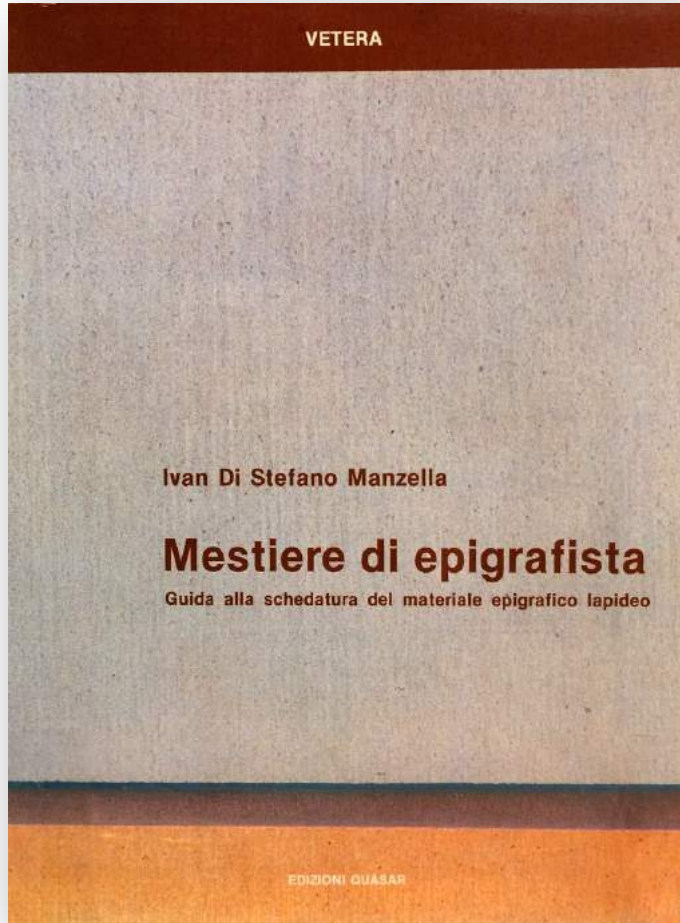

1987

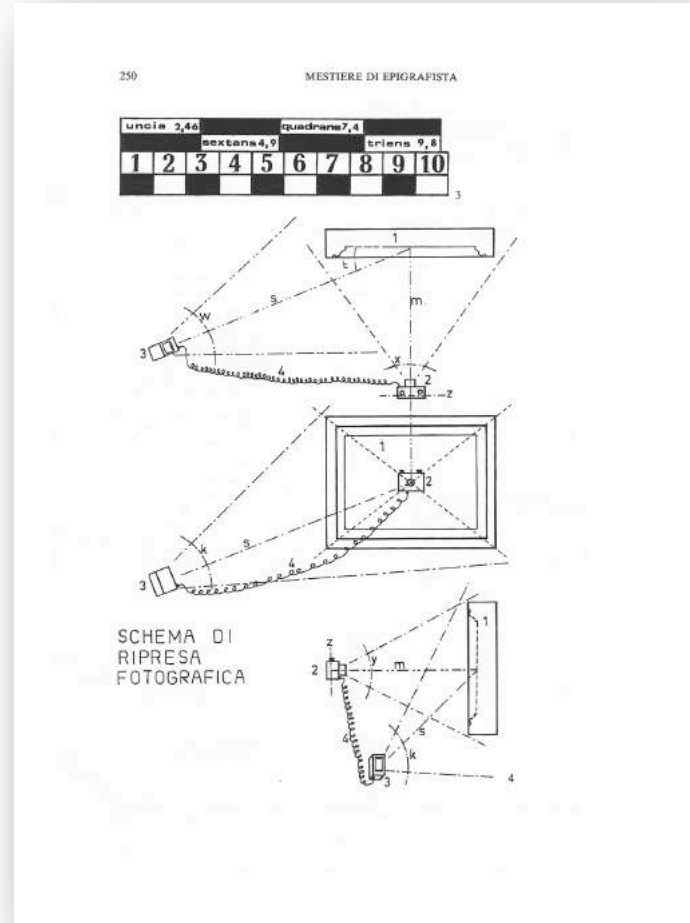

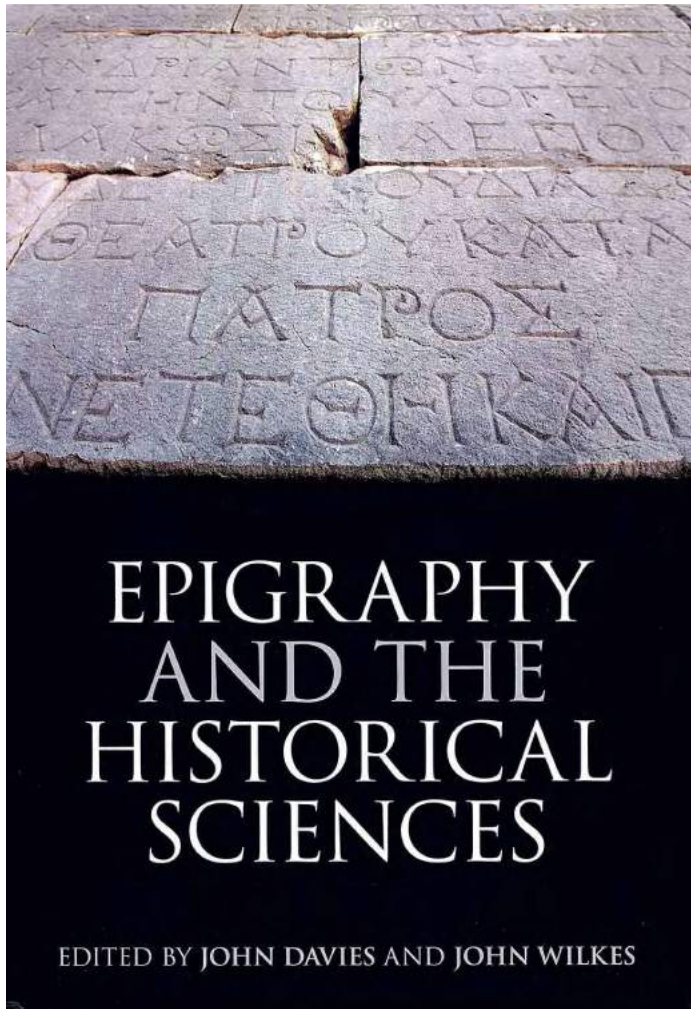

2012

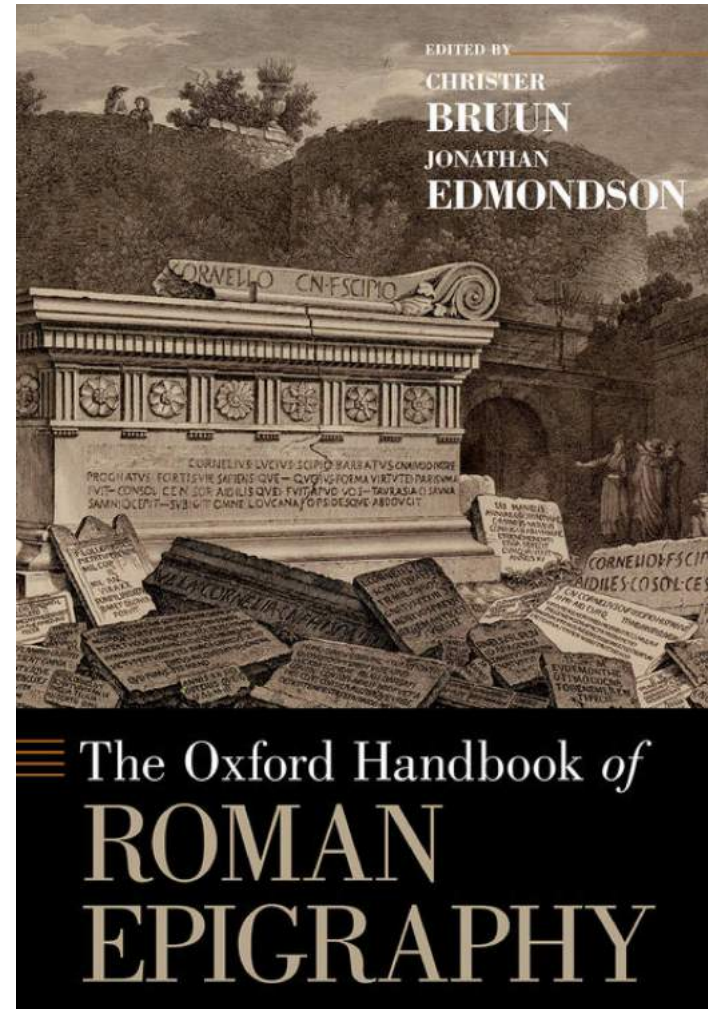

2015

Digital Epigraphy

Written and designed by Krisztián Vértés

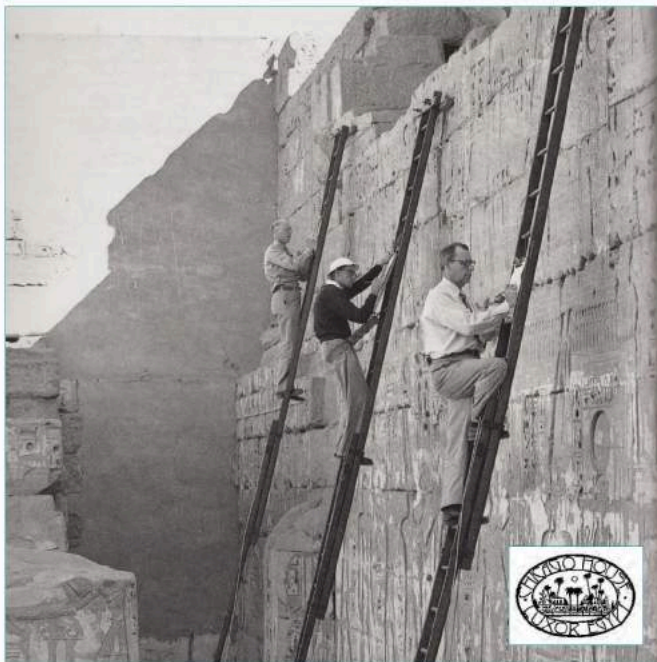

The Epigraphic Survey of the Oriental Institute,
University of Chicago

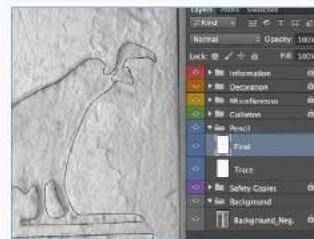

Photo by S. Ostroud

(1) Setup made for working on the tablet



(4) Searching for the right curve with the Brush tool



(2) Template with the Pencil Layers included

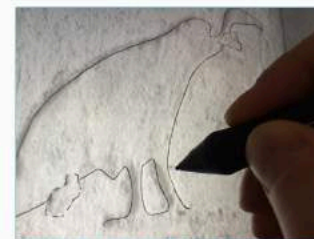

(5) Using a "soft" eraser for refining edges

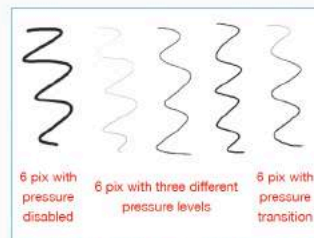

6 pix with pressure disabled 6 pix with three different pressure levels 6 pix with pressure transition

(3) Changes in line weights by adding pressure



(6) Work path indicating pencil line placement

2014

Current Issue

» 2016: 10.4

Preview Issue

» 2017: 11.1

Previous Issues

» 2016: 10.3

» 2016: 10.2

» 2016: 10.1

» 2015: 9.4

» 2015: 9.3

» 2015: 9.2

» 2015: 9.1

» 2014: 8.4

» 2014: 8.3

» 2014: 8.2

» 2014: 8.1

» 2013: 7.3

» 2013: 7.2

» 2013: 7.1

» 2012: 6.3

» 2012: 6.2

» 2012: 6.1

» 2011: 5.3

» 2011: 5.2

» 2011: 5.1

» 2010: 4.2

» 2010: 4.1

» 2009: 3.4

» 2009: 3.3

» 2009: 3.2

» 2009: 3.1

» 2008: 2.1

» 2007: 1.2

» 2007: 1.1

Indexes

» Title

» Author

Changing the Center of Gravity: Transforming Classical Studies Through Cyberinfrastructure
2009
Volume 3 Number 1

2009 3.1 | XML | Discuss (0 Comments)

Epigraphy in 2017

Hugh Cayless <hcayless_at_email_dot_unc_dot_edu>, University of North Carolina
Charlotte Roueché <charlotte_dot_roueche_at_kcl_dot_ac_dot_uk>, King's College London
Tom Elliott <tom_dot_elliott_at_nyu_dot_edu>, New York University
Gabriel Bodard <gabriel_dot_bodard_at_kcl_dot_ac_dot_uk>, King's College London

Abstract

Epigraphy as a discipline has evolved greatly over the centuries. Many epigraphists in the last 20 years have been investigating how to use digital technology to advance their research, but until the present decade, these undertakings were restrained by aspects of the technology. The late 1990s will be seen as a watershed moment in the transition from print-based to born-digital epigraphic publication. At present, the majority of new editions are still published solely in print, but by 2017 we believe this circumstance will change drastically. The history of epigraphy makes it quite clear that such transitions are natural to the discipline.

1. Background

Epigraphy is an area of study of the Graeco-Roman past which has been through centuries of change. Scholars in 8th century Constantinople tried to use inscriptions to make sense of their history:

We have written this after reading it from inscriptions on marble tablets or after making enquiries of those who have read it. [Cameron and Herrin 1984, 24]

To such viewers, in common with Pausanias in the second century, the main function of inscriptions was as labels, to explain monuments and statues, although the medieval viewers came to believe that there were also occult messages, to be deciphered by the learned. [Dagron 1984]

This basic tradition of reading an inscription as a label has never really been eliminated. But the awakening of scholarship in the Renaissance led western scholars — most strikingly, Cyriacus of Ancona — to start recording inscribed texts more fully. In western Europe, the relevance of Latin inscribed texts to local history was evident, and the style of such texts came increasingly to influence the funerary epigraphy of the period. The development of a standard education for gentlemen in both Latin and Greek meant that, as travel in the eastern Mediterranean increased in the 18th and 19th century, inscriptions started to be transcribed by visitors who were not necessarily classical scholars: William Sherard, who transcribed many important texts while he was British Consul at Smyrna in the early 1700s was a botanist who later endowed a Chair of Botany at Oxford (<http://www.oxforddnb.com/view/article/25355?docPos=2&fromAuth=1>).

These travelers were working in difficult circumstances: Charles Fellows reports that there was an outbreak of plague in the area when he visited Aphrodisias; they even had to be sparing of paper (Wood copied some texts into the margins of the volume of Homer that he was carrying). It is astonishing that their copies were so often excellent. They tended to copy complete texts — rather than fragments — and did not spend much time recording details beyond the text itself. For examples, see the notebooks of John Gandy-Deering, from a visit to Aphrodisias in 1812: <http://insaph.kcl.ac.uk/>

<https://goo.gl/Oxpd9J>

sourceforge [Browse](#) [Enterprise](#) [Blog](#) [Deals](#) [Help](#) [Create](#) [Log In](#) or [Join](#)

[SOLUTION CENTERS](#) [Go Parallel](#) [Resources](#) [Newsletters](#) [Cloud Storage Providers](#) [Business VoIP Providers](#) [Call Center Providers](#)



[Home](#) / [Browse](#) / [EpiDoc: Epigraphic Documents in TEI XML](#) / [Home](#)

EpiDoc: Epigraphic Documents in TEI XML

XML text markup for ancient documents
Brought to you by: [gabrielbodard](#), [hcayless](#), [paregorios](#)

[Summary](#) [Files](#) [Reviews](#) [Support](#) [Home](#) [Markup List](#) [Code \(SVN\)](#) [Request Features](#) [Report Bugs](#) [CVS \(old - don't use\)](#)

[Wiki Home](#)
[Browse Pages](#)
[Browse Labels](#)
[Formatting Help](#)

Home   

Authors: 



EpiDoc is an international, collaborative effort that provides guidelines and tools for encoding scholarly and educational editions of ancient documents. It uses a subset of the [Text Encoding Initiative's](#) standard for the representation of texts in digital form and was developed initially for the publication of digital editions of ancient inscriptions (e.g. [Inscriptions of Aphrodisias](#), [Vindolanda Tablets](#)). Its domain has expanded to include the publication of papyri and manuscripts (e.g. [Papyri.info](#)). It addresses not only the transcription and editorial treatment of texts themselves, but also the history and materiality of the objects on which the texts appear (i.e., manuscripts, monuments, tablets, papyri, and other text-bearing objects).

Latest Release of all EpiDoc code: 8.22 (August 2016)

Core EpiDoc Components

- [EpiDoc Guidelines](#): recommendations for markup of transcription, descriptive features, etc. ([About](#))
- [EpiDoc Schema](#): the TEI-derived schema against which EpiDoc XML should be validated
- [EpiDoc Example Stylesheets](#): for transforming EpiDoc XML to HTML, text or ODF

Learn more

- [About EpiDoc](#)

<https://sourceforge.net/p/epidoc/wiki/Home/>

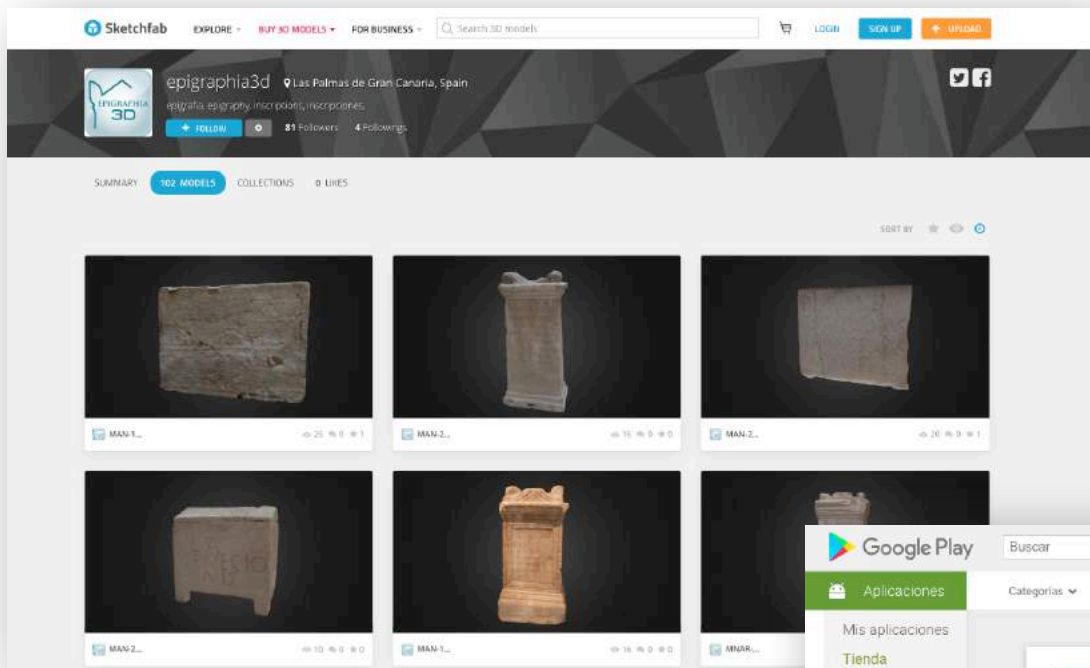

2014

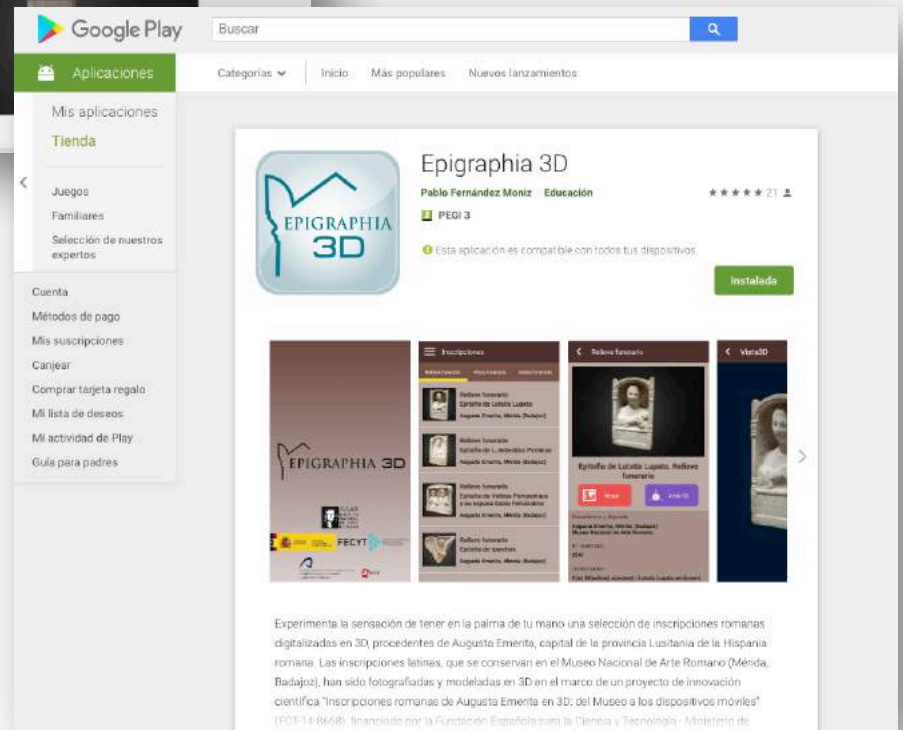

2016



Ashmolean Latin
@AshmoleanLatin

Siguiendo

Replicas for new education sessions are coming along. As well as the gorgeous clay replicas, we're doing 3D prints of some favourites.

Traducir del inglés



12:33 - 27 oct. 2017

10 Retweets 19 Me gusta



Steven Dey

1 10 19

ALEXANDER
D V I L A R S A M A
C E I L O O V E R A N N O S
X X A N N I S P R O M O M
N I O R V A A M I C V S
D O T U M I O T V A I N T E R
D I C A E I S

D V I L M A R C I O
P A C E T O F I L I O D
V I C I S S I M O
F E C I T A R O
D O P E T A
T E R A I N
C I S S I M O
O V E R I T A N N O S
X V M V I I I D M I I



Epigrafía digital

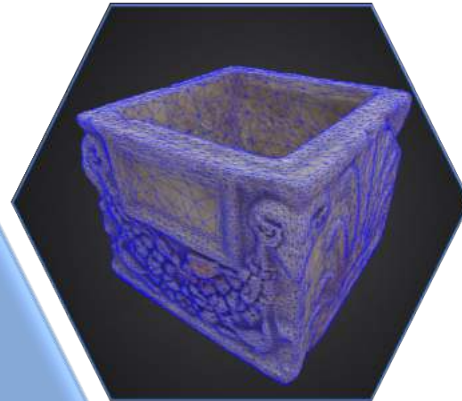

Trasvase de la investigación a la docencia

```
<b n="1" />
<gap reason="lost" ex
<lb n="2" />
<supplied reason="lost"
nobilissi
/supplied>
nclear reason=""
```

Alfabetización digital



digitalclassicist

page [discussion](#) [view source](#) [history](#)

- » Home
- » FAQ
- » Projects
- » Tools
- » Discussion
- » Members
- » Events

Navigation

- » Categories
- » Recent changes
- » Random page

Search

Toolbox

- » What links here
- » Related changes
- » Special pages
- » Printable version
- » Permanent link

EpiDoc Workshops have been run on several occasions over the past few years, with the intention of disseminating skills and experience and encouraging discussion on the topic of TEI markup for the encoding of epigraphic, papyrological, and other ancient texts.

Contents [hide]

- 1 Training programme
- 2 If you want to run an EpiDoc workshop
- 3 Future events
- 4 Past Events
- 5 Notes
- 6 Training Materials
 - 6.1 Current
 - 6.2 other materials not used recently
- 7 Contact

Training programme

The most recent training programme, for the March 2019 workshop in Ankara, can be found at: <http://goo.gl/FbwxhO>

The training programme, for the May 2019 workshop in Bologna, can be found [here](#) ☺

If you want to run an EpiDoc workshop

If you would like to run or host an EpiDoc training workshop at some point, please in the first instance contact the Markup list to canvass the possible trainers for their availability.

Please be prepared to:

- » raise money to fund travel and accommodation (at least) for two or preferably three experienced trainers to visit and run the workshop
 - » normally you should be prepared to pay the trainers a standard daily rate for their time as well
 - » a funded project should enquire for consultancy rates; a limited number (1-2) of expenses-only workshops will be run per year
- » begin planning the workshop at least 6 months ahead, and be flexible
- » provide a seminar room with space for 15-20 participants to sit comfortably, with wireless internet access, data projection and plenty of power sockets/extension cables

Future events

- » EpiDoc and 3D imaging workshop, Bilkent University and BIAA, Ankara, March 25–28, 2019. ([programme ds](#))
- » EpiDoc and morphosyntactic annotation workshop, Helsinki, April 8–11, 2019.
- » Epigraphy and digital epigraphy training, Institute of Classical Studies, London, April 29–May 3, 2019.
- » EpiDoc and epigraphy.info, Universität Wien, Wien, TBC in May 2019.
- » EpiDoc workshop, Università di Bologna, Bologna, May 29-31, 2019 (in Italian).
- » Berlin, September 2019
- » Zurich, September 2019

https://wiki.digitalclassicist.org/EpiDoc_Workshops

CONGRESO INTERNACIONAL
***El patrimonio epigráfico en la era digital:
 Documentación, análisis y socialización***

ORGANIZAN:
 Isabel Velázquez Soriano (Universidad Complutense)
 David Espinosa Espinosa (Universidad de Santiago de Compostela)
 Rosario Hernando Sobrino (Universidad Complutense)
 Estela García Fernández (Universidad Complutense)



20 y 21 de junio de 2019
 Salón de Grados
 Facultad de Geografía e Historia
 Universidad Complutense

**Programa de Doctorado
 en Estudios del Mundo
 Antiguo (UCM-UAM)** 





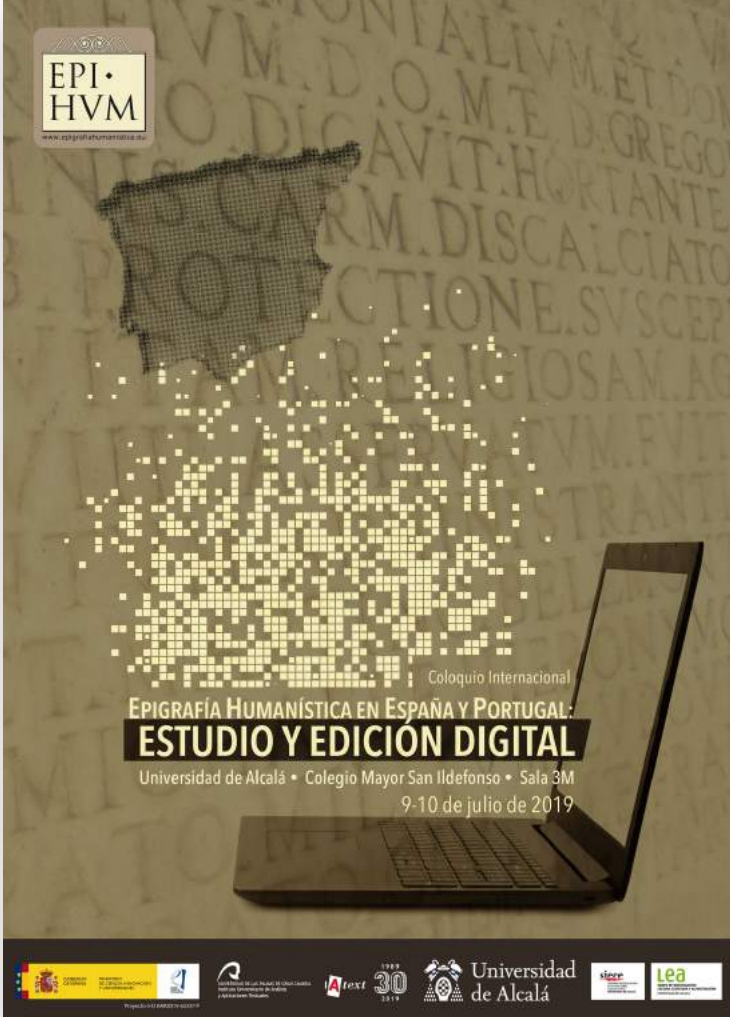

20-21/06/2019



EPI•HVM
 www.epigrafiahumanistica.es

Coloquio Internacional
**EPIGRAFÍA HUMANÍSTICA EN ESPAÑA Y PORTUGAL:
 ESTUDIO Y EDICIÓN DIGITAL**
 Universidad de Alcalá • Colegio Mayor San Ildefonso • Sala 3M
 9-10 de julio de 2019

9-10/07/2019

A poster for a training school. The background is a blue sky with a cityscape of Verona at sunset, with the Adige river winding through it. In the center, a large, red, wireframe 3D model of an ancient stone block is shown. The text is in white and black, with some elements in red. At the top, there are logos for the University of Verona, the Municipality of Verona, and the University of Applied Sciences. A QR code is on the right side. At the bottom, the dates 'Verona [2-5] 2019 Settembre' are displayed, along with logos for the European Union and the Italian Ministry of Education.

UNIVERSITÀ di VERONA

my

Comune di Verona

UNIVERSITÀ degli STUDI DI VERONA

30 1989 2019

Training School

DIGITALIZZAZIONE
DEL SUPPORTO EPIGRAFICO
E STRUMENTI INFORMATICI
PER LO STUDIO
DELLE LINGUE ANTICHE

www.alteritas.it

Verona [2-5] 2019 Settembre

<http://www.alteritas.it/http-www-alteritas-it-alteritas-training-school/>

LA VIDA POR AQUÍ

“La Universidad te enseña tarde”

Universitarios del colegio mayor Covarrubias de Madrid ponen nota al mundo, al país y a sus estudios



JUAN CRUZ

Madrid - 22 MAR 2019 - 21:05 CET



Desde la izquierda, Alonso, Mónica, Irene, Manuel G., Manuel J. y Carmela, en el colegio mayor Covarrubias de Madrid el miércoles. ULY MARTÍN

El Plan Bolonia acortó las carreras, y universitarios que empiezan o están a punto de acabar se sienten decepcionados. "La Universidad te enseña siempre un poco tarde", dice Carmela García, asturiana, tercero en Ingeniería Industrial de Diseño Industrial y de Desarrollo de Producto.

Jazztel Llama gratis
900 833 712

La Doblemente

IRRESISTIBLE

¡Ampliamos!

Móvil
25GB
2 líneas
+ llamadas ilimitadas

Fibra
100Mb
+ llamadas ilimitadas



master humanidades digitales



Todo

Imágenes

Noticias

Maps

Videos

Más

Configuración

Herramientas

Aproximadamente 513.000 resultados (0,73 segundos)

Máster Universitario en Historia y Humanidades Digitales - Upo

<https://www.upo.es/postgrado/Master-Oficial-Historia-y-Humanidades-Digitales>

Máster Universitario en Historia y Humanidades Digitales de la Universidad Pablo de Olavide, de Sevilla. ¡Infórmate!

Máster Universitario en Humanidades Digitales - Universidad CEU ...

<https://www.uspceu.com/oferta.../master-universitario-en-humanidades-digitales>

Máster Universitario en Humanidades Digitales USP CEU. Presencial o Semipresencial. Único título oficial que conecta con las nuevas tecnologías.

Máster Universitario en Humanidades Digitales – LINHD

linhd.uned.es/p/dh-master-humanidades-digitales-2019/

Máster Universitario en Humanidades Digitales. Fechas: 2019-2020. Este programa, denominado de "Master en Humanidades Digitales" es un Título Propio de ...

Máster de Humanidades Digitales - Universitat de Barcelona

https://www.ub.edu/web/ub/es/estudis/oferta_formativa/master.../H/.../index.html

Créditos ECTS: 60. Idioma de docencia: Catalán y castellano. Precio Orientativo: 46,50 euros por crédito (82 euros para estudiantes de fuera de la UE y no ...

Máster en Humanidades Digitales. Universitat Autònoma de Barcelona

www.universia.es › Estudios universitarios

Máster en Humanidades Digitales. Conoce toda la información y datos de interés que necesitas saber sobre este estudio en Universitat Autònoma de ...

Study at King's

[Undergraduate](#) | [Postgraduate](#) | [More courses](#) | [International](#) | [Why King's?](#) | [Accommodation](#) | [Student life](#) | [Visit King's](#)

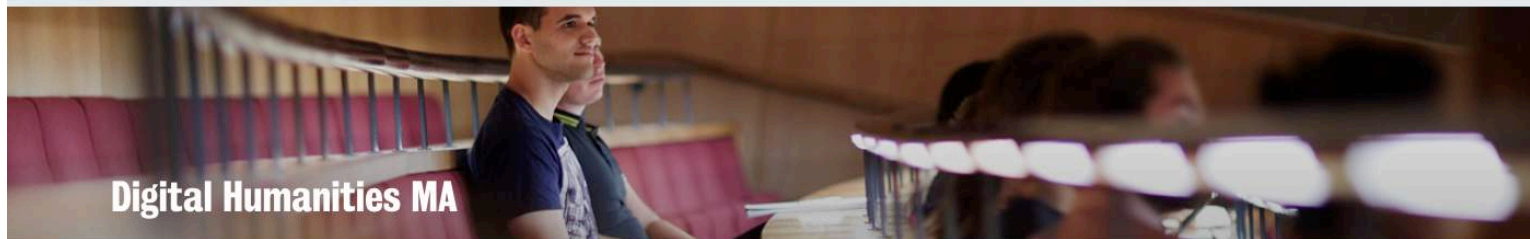

Digital Humanities MA

[Overview](#)[Course detail](#)[Entry requirements](#)[Fees & funding](#)[Career prospects](#)[Testimonials](#)[Next steps](#)[Apply now](#)

Overview

Our course in Digital Humanities brings digital theory and practice to the study of human culture: from history, English and music to museums, digital publishing and more.

Digital technology provides many new opportunities and challenges to those working with textual, visual or multimedia content. Our course studies the history and current state of the digital humanities, exploring their role in modelling, curating, analysing and interpreting digital representations of human culture in all its forms.

Leads to careers in cultural heritage, publishing and web-based businesses.

Key information

Further details

Application status Open

Duration

One year FT, two years PT, September to September.

Study mode Full-time, Part-time

Credit value UK 180/ECTS 90

Course intake 20-25 per annum

Course leaders

Paul Spence: paul.spence@kcl.ac.uk;

Admissions Tutor: Marta Musso:



ALMA MATER STUDIORUM
UNIVERSITÀ DI BOLOGNA

SECOND CYCLE DEGREE/TWO YEAR MASTER IN DIGITAL HUMANITIES AND DIGITAL KNOWLEDGE

HOME

PROGRAMME

ADMISSION

STUDYING

OPPORTUNITIES

NOTICE BOARD

CONTACTS

IT

EN



OVERVIEW

HOW TO ENROL



PROGRAMME TYPE

Laurea Magistrale (Second cycle degree/Two year Master - 120 ECTS)



PLACE OF TEACHING

Bologna



LANGUAGE

English



TYPE OF ACCESS

Open access with assessment of personal



DEGREE PROGRAMME CLASS

LM-43 - Information technology methods



DEGREE PROGRAMME DIRECTOR

Francesca Tomasi

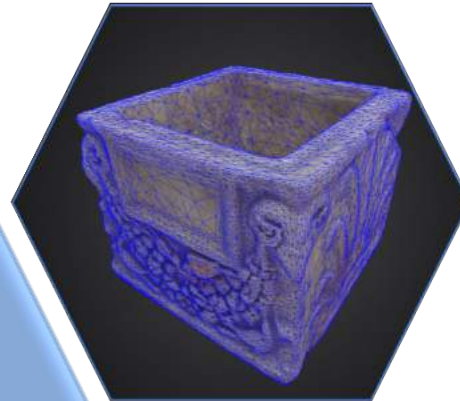

Epigrafía digital

Trasvase de la investigación a la docencia

```
<span n="1" />  
<gap reason="lost" ex  
<span n="2" />  
<supplied reason="lost"  
nobilissi  
/supplied>  
<span n="3" />  
<supplied reason="lost" />
```

Alfabetización digital



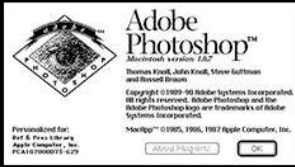

Photoshop 1



Photoshop 2



Photoshop 2.5



Photoshop 3



Photoshop 4



Photoshop 5



Photoshop 5.5



Photoshop 6

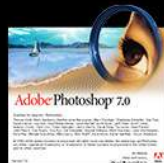

Photoshop 7



Photoshop CS



Photoshop CS2



Photoshop CS3



Photoshop CS4



Photoshop CS5



Photoshop CS6



Photoshop CC



Photoshop CC (2014.1)



Photoshop CC (2014.2)





PS1



PS2



PS 2.5



PS3



PS4



PS5



PS 5.5



PS6



PS7



PS CS1



PS CS2



PS CS3



PS CS4



PS CSS



PS CS6



PS CC



Competencias digitales básicas

- 
- Fotografía digital nivel inicial (Photoshop)
 - Modelado 3D básico con Meshlab y Photoscan
 - Introducción al procesamiento básico con Blender
 - Georreferenciación básica (GoogleMaps, OpenStreetMaps)
 - Introducción a TEI-XML (Epidoc)
 - Gestores bibliográficos y marcadores sociales
 - Publicación web formato Widget y editores WYSIWYG básico (WordPress)

Epigrafía Augusta Emerita 3D

Distribución espacial de las inscripciones romanas del Museo Nacional de Arte Romano (MNAR), digitalizadas y modeladas en 3D en el más
94 vistas

Todos los cambios se han guardado en Drive.

Añadir capa Compartir

Cupas

Estilos individuales

5. Epitafio de XXXXXX

6. Epitafio de Flavia Patricia

Bronces

Estilos individuales

4. Tabula hospitalis

Estelas



Mapa base

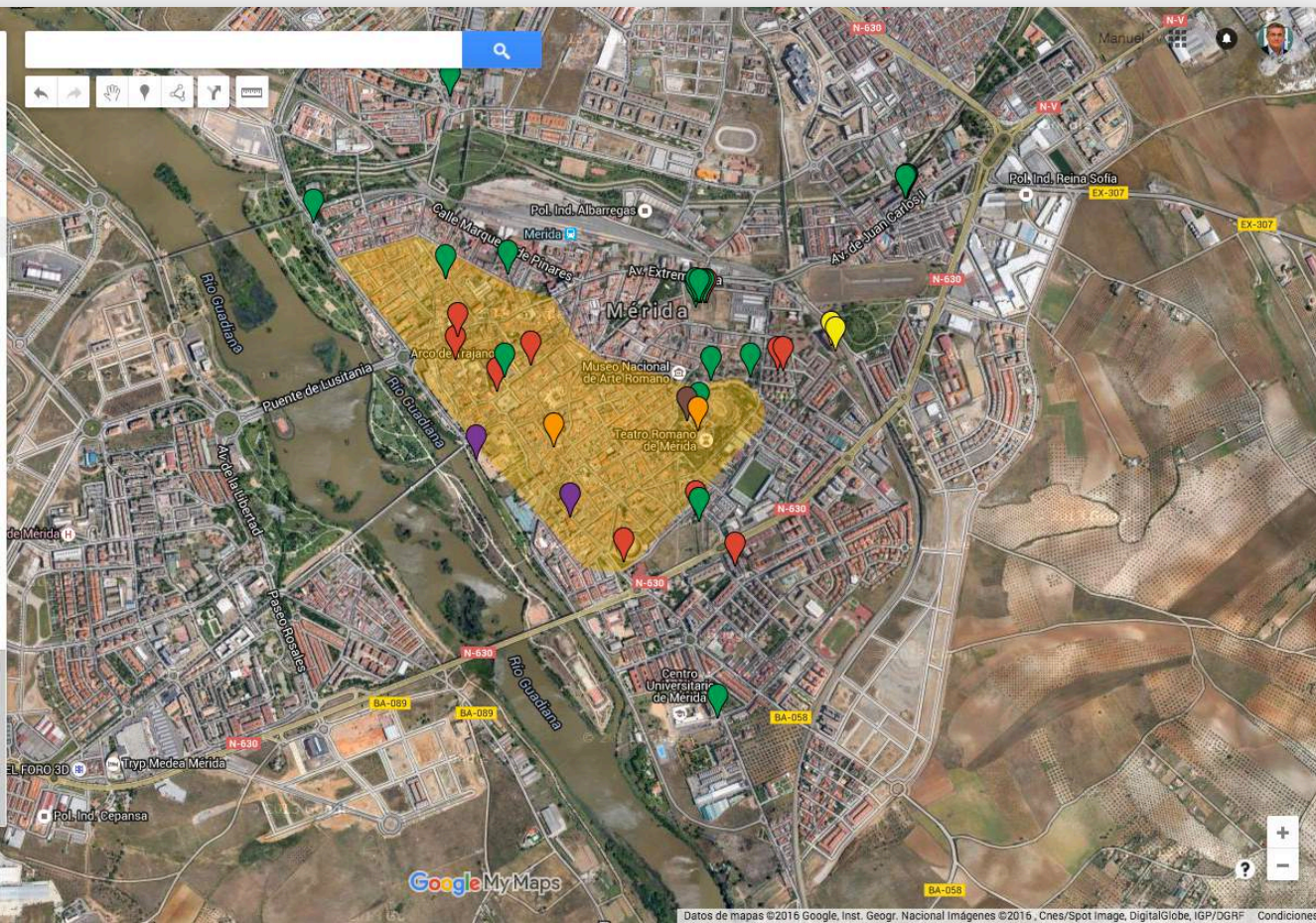

Epigrafía Augusta Emerita 3D

Distribución espacial de las inscripciones romanas del Museo Nacional de Arte Romano (MNAR), digitalizadas y modeladas en 3D en el más
94 vistas

Todos los cambios se han guardado en Drive.

Añadir capa Compartir

Aras

Estilos individuales

- 1. Epitafio de Lutatia Lupata
- 11. Epitafio de G. Lancius Iuli...
- 14. Epitafio de Baebius Florus
- 16. Dedicatoria a Sigerio Stili...
- 18. Dedicatoria a Dea Sancta...
- 20. Dedicatoria a Dea Sancta
- 31. Epitafio de M. Argentariu...
- 32. Epitafio de Iulia Glyconis
- 34. Epitafio de Fabia Veneria
- 36. Epitafio de Daphnus
- 37. Epitafio de L. Norbanus N...
- 38. Epitafio de Pusinca
- Augusta Emerita

Placas

Estilos individuales

- 7. Epitafio de Sentia Amarantis
- 9. Epitafio de Zosimus, benef...

14. Epitafio de Baebius Florus



1 de 1

www.epigraphia3d.es/3d-51.html

Procedencia: Palacio de Burnay

38.91672, -6.34671



Google My Maps

Datos de mapas ©2016 Google, Inst. Geogr. Nacional Condiciones

Competencias digitales avanzadas

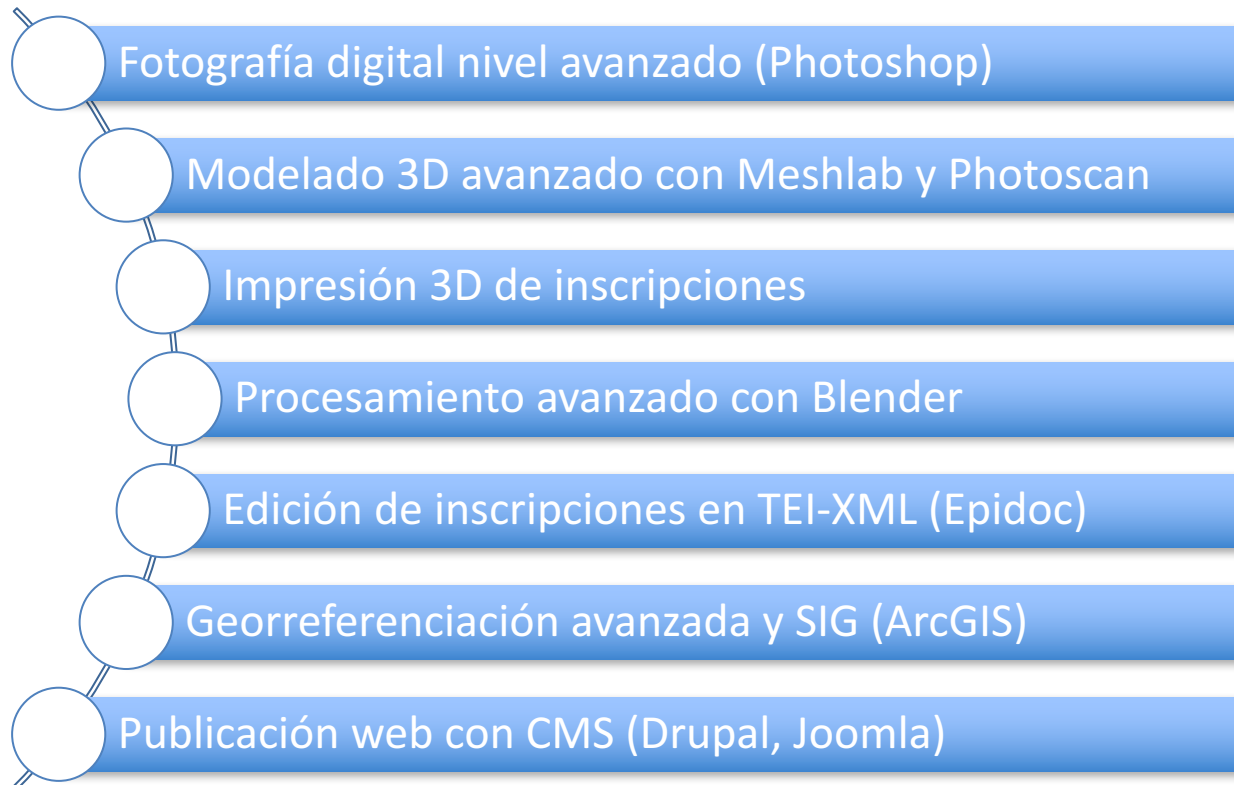
- 
- Fotografía digital nivel avanzado (Photoshop)
 - Modelado 3D avanzado con Meshlab y Photoscan
 - Impresión 3D de inscripciones
 - Procesamiento avanzado con Blender
 - Edición de inscripciones en TEI-XML (Epidoc)
 - Georreferenciación avanzada y SIG (ArcGIS)
 - Publicación web con CMS (Drupal, Joomla)

Leiden conventions and EpiDoc

Leiden is also a markup language:

| | |
|---------|--|
| ... | Illegible letters, not restored by editor. |
| ᵃᵇ | Letters ambiguous without their context. |
| [...] | Letters missing, not restored by editor. |
| [abc] | Letters missing, restored by editor. |
| ⟨...⟩ | Letters erroneously omitted, not restored. |
| ⟨abc⟩ | Letters erroneously omitted, restored by editor. |
| a(bc) | Abbreviation expanded by editor. |
| {abc} | Letters considered superfluous by editor. |
| [[abc]] | Deletion which can be restored. |

Mapping Leiden to EpiDoc:

| | |
|---------|---|
| ... | <code><gap reason="illegible" extent="unknown"/></code> |
| ᵃᵇ | <code><unclear>ab</unclear></code> |
| [...] | <code><gap reason="lost" extent="unknown"/></code> |
| [abc] | <code><supplied reason="lost">abc</supplied></code> |
| ⟨...⟩ | <code><gap reason="omitted" extent="unknown"/></code> |
| ⟨abc⟩ | <code><supplied reason="omitted">abc</supplied></code> |
| a(bc) | <code><expan><abbr>a</abbr><ex>be</ex></expan></code> |
| {abc} | <code><surplus>abc</surplus></code> |
| [[abc]] | <code>abc</code> |

¿Hacia un Marco Común de Competencias en Epigrafía Digital?

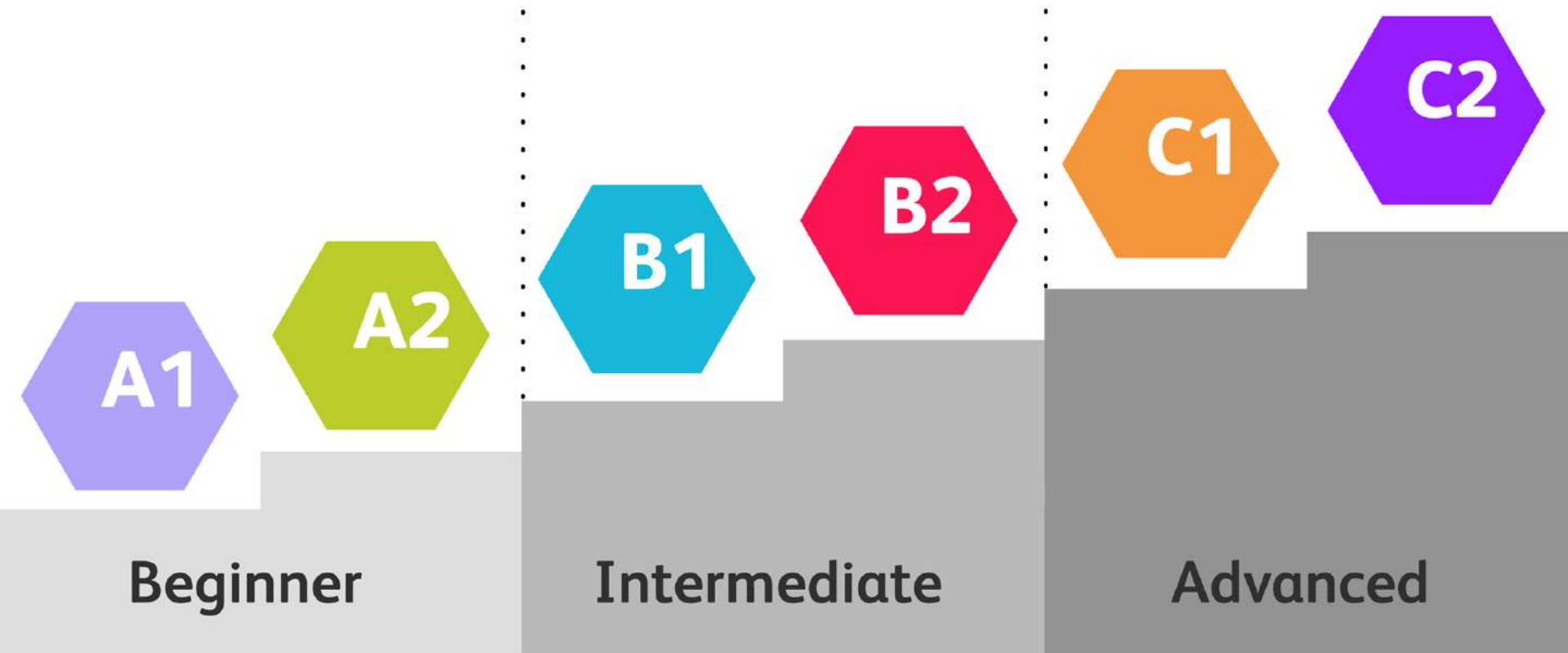

¿Hacia un mercado de acreditaciones?



Aprender habilidades esenciales con los planes de estudio de Microsoft Digital Literacy

Microsoft Digital Literacy tiene como objetivo enseñar y evaluar los conceptos y habilidades básicos de la informática para que las personas puedan utilizar la tecnología informática en su vida cotidiana y desarrollar nuevas oportunidades sociales y económicas para ellos, sus familias y

Introducción

Acceso al programa de cursos

Blog > Reconocimiento de la Competencia Digital Docente

31-10-2017

A partir de hoy 31 de octubre de 2017, el Ministerio de Educación, Cultura y Deporte, a través del Instituto Nacional de Tecnologías Educativas y Formación del Profesorado (INTEF), abre un servicio en línea para el reconocimiento de la competencia digital docente: el **Portafolio de la Competencia Digital Docente**.

El **Portafolio de la Competencia Digital Docente** es un servicio para la adquisición, el desarrollo, el reconocimiento y la mejora de la competencia digital de los docentes a través de la autoevaluación continua y del registro actualizable de experiencias de enseñanza, aprendizaje y formación. Se trata de un instrumento de aprendizaje a lo largo de la vida, mediante el cual cualquier docente, o futuro docente, puede conocer su nivel de competencia digital y mejorarlo a través de un itinerario formativo recomendado, además de solicitar anualmente el reconocimiento de su nivel competencial, que el INTEF avalará mediante la emisión de credenciales digitales abiertas.

Categorías: Blog, Formación y colaboración

Etiquetas: Competencia digital, Competencias, Credenciales, Insignias digitales, Portafolio

Tuitéalo

Nuevas lecturas ...

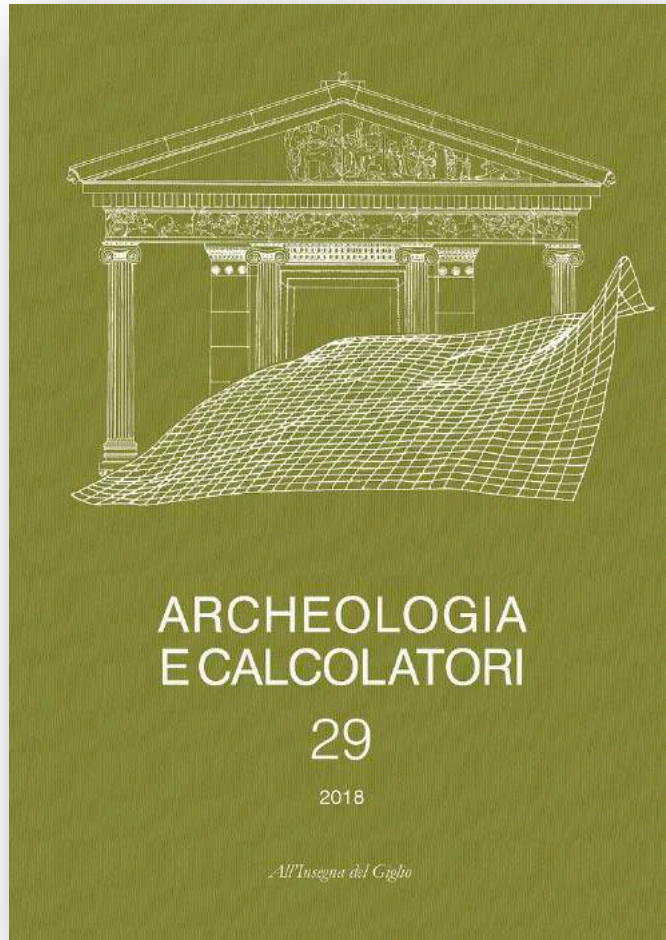

1990 —

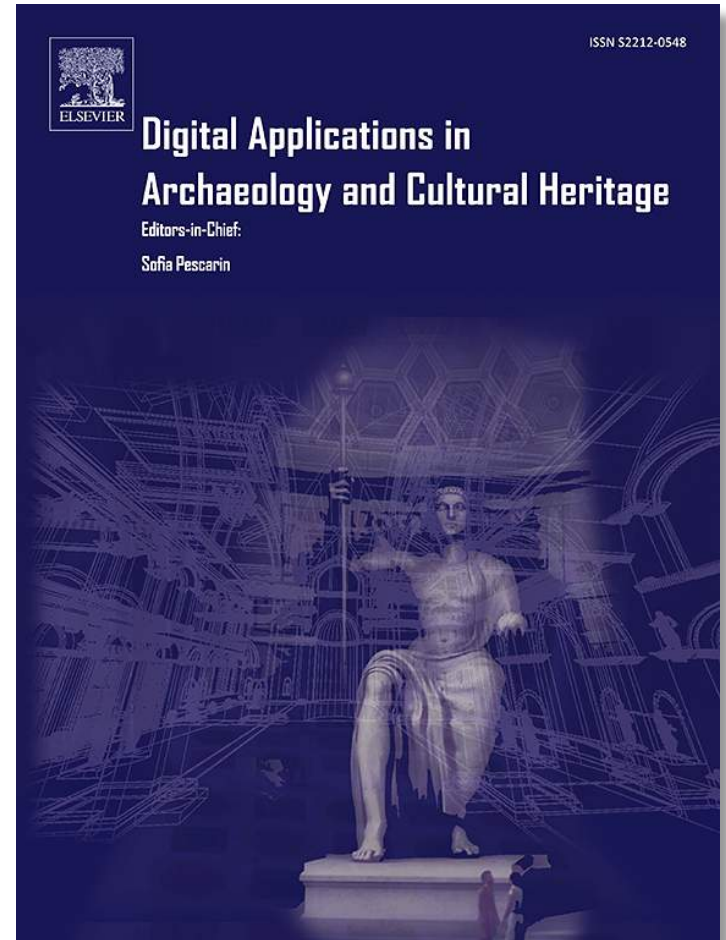

2014 —

Tutoriales ...

The image shows a YouTube channel page for Pablo Serrano, who has 1,010 subscribers. The page is in Spanish and displays a grid of 15 video thumbnails. The channel name 'Pablo Serrano' and subscriber count '1.010 suscriptores' are visible at the top. The navigation bar includes 'INICIO', 'VÍDEOS', 'LISTAS DE REPRODUCCIÓN', 'COMUNIDAD', 'CANALES', and 'MÁS INFORMACIÓN'. The left sidebar contains navigation options like 'Inicio', 'Tendencias', 'Suscripciones', 'Biblioteca', 'Historial', 'Ver más tarde', 'Videos favoritos', and 'Preferidos'. The video thumbnails are arranged in three rows of five. Each thumbnail includes a video preview, a duration, a title, and view statistics.

| Thumbnail | Duration | Title | Views | Time |
|-----------|----------|--|---------------------|---------------|
| | 21:01 | Blender 2.80: las novedades más importantes | 99 visualizaciones | Hace 1 mes |
| | 1:05:17 | Curso de Inkscape, 2ª Edición | 97 visualizaciones | Hace 2 meses |
| | 16:42 | Reducir el peso de un modelo sin perder resolución: Textu... | 269 visualizaciones | Hace 6 meses |
| | 1:11:11 | 1º Hangout Curso Introducción a la... | 191 visualizaciones | Hace 6 meses |
| | 56:11 | Curso de Introducción a la Fotogrametría - 1º Hangout | 156 visualizaciones | Hace 6 meses |
| | 42:05 | Tijeras: complemento al Bloque 2 del Curso de... | 105 visualizaciones | Hace 8 meses |
| | 1:09:20 | 2º Hangout Curso Avanzado de Fotogrametría | 208 visualizaciones | Hace 10 meses |
| | 4:13 | Mostrar la topología de una malla con Wireframe | 115 visualizaciones | Hace 10 meses |
| | 6:16 | Secciones transversales mediante modificador... | 122 visualizaciones | Hace 10 meses |
| | 1:17:36 | 1º Hangout Curso Avanzado de Fotogrametría | 287 visualizaciones | Hace 10 meses |
| | 1:09:36 | 1º Hangout curso Introducción a Blender y... | ... | ... |
| | 1:22 | dron baños | 110 visualizaciones | ... |
| | 48:20 | 3º Hangout Curso de Introducción a la... | ... | ... |
| | 55:31 | 2º Hangout Curso de Introducción a la... | ... | ... |
| | 0:09 | osa vid | 78 visualizaciones | Hace 1 año |



UNIVERSIDAD DE LAS PALMAS DE GRAN CANARIA
Instituto Universitario de Análisis
y Aplicaciones Textuales



Manuel Ramírez Sánchez

Universidad de Las Palmas de Gran Canaria
Instituto Universitario de Análisis y Aplicaciones Textuales

 manuel.ramirez@ulpgc.es

 [@manuelramirez](https://twitter.com/manuelramirez)